

CORNICE THE CONCORD

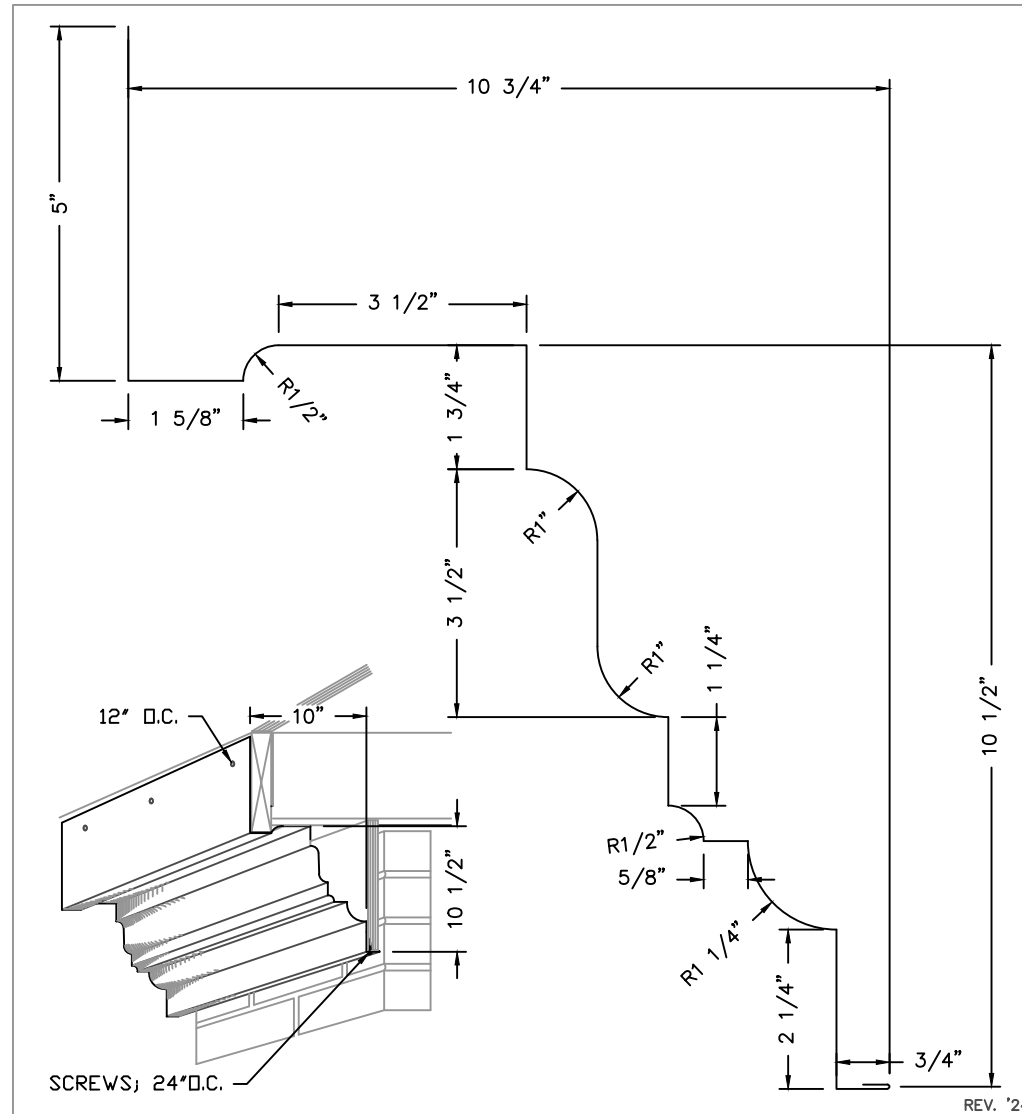

AVAILABLE MATERIALS: PREWEATHERED ZINC PREFINISHED ALUMINUM
 COPPER FREEDOM GRAY COPPER PAINT GRIP STEEL

DIMENSIONS: 10 FOOT LONG. (SEE DRAWING FOR DIMENSION PROFILE & FRAMING)
 INSTALLATION: FASTEN AT TOP AND BOTTOM OF CORNICE. 10" HORIZONTAL AND
 10 1/2" VERTICAL DIMENSIONS ARE CRITICAL FOR CORRECT FIT.
 OPTION FOR CURVING IN COPPER AND PRE-WEATHERED ZINC.
 AVAILABLE WITH MITERS AND END CAPS.